

## INSTALLATION GUIDE

CVR-1

**45 minutes**  
Normal Install Time

Keep an eye out for these icons:

**IMPORTANT!**  
Important installation information

**Helpful Hints**  
Tips to assist installation

### PARTS INCLUDED:



Cab Panel



Center Panel

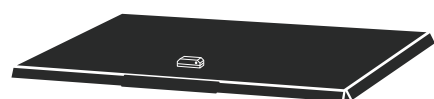

Tailgate Panel



Bed-Rail  
Edge Trim (4)



1/8" Hex Key

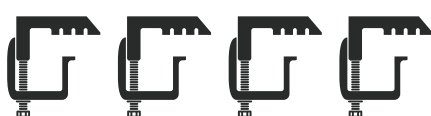

Cap Clamps (4)



Safety Catch



Gas Springs (4)

### TOOLS REQUIRED:



Ratchet Wrench



9/16" Socket



7/16" Socket



Utility Knife  
(Frontiers only)

### PRE-INSTALLATION NOTES:

1. If you are installing a **cab guard** or **headache rack**, you should mount it prior to mounting your DiamondBack. Refer to its installation guide for details.
2. If you are installing a **Side-Loading ATV Carrier** on cargo bed longer than 6 feet, you must mount the **center-panel adapter bars** prior to installing your DiamondBack HD. Refer to the **Side Adapter Bars Installation Guide** for details.
3. It's possible for one person to install a DiamondBack solo, but the whole process, especially positioning the panels and adjusting the lock rods, is much easier with two people.

## MOUNT THE PANELS

- 1 Place the **center panel** across the center of bed, cheated slightly toward the tailgate.

**!** Make the sure the arrow sticker on the underside of the center panel is pointing toward the tailgate.

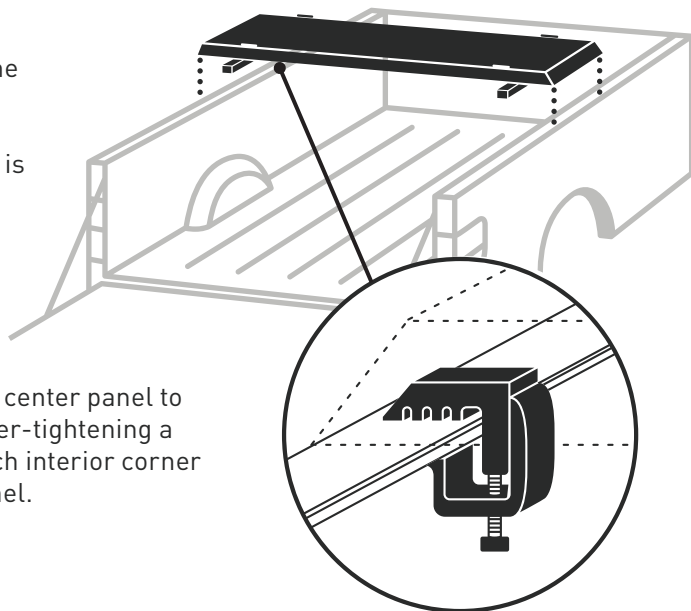

- 2 Loosely affix the center panel to the truck by finger-tightening a **cap clamp** at each interior corner of the center panel.

- 3 Slide the **tailgate panel** onto the center panel by mating their hinges. Close it slowly.

**★** Mating hinges is easiest when you line up the longer, left hinge pin first.

**!** To avoid hinge damage, do not close the panel until the hinges are fully mated: Tilt the panel **past 90°** and push to the left until the hinge lock tabs interlock.

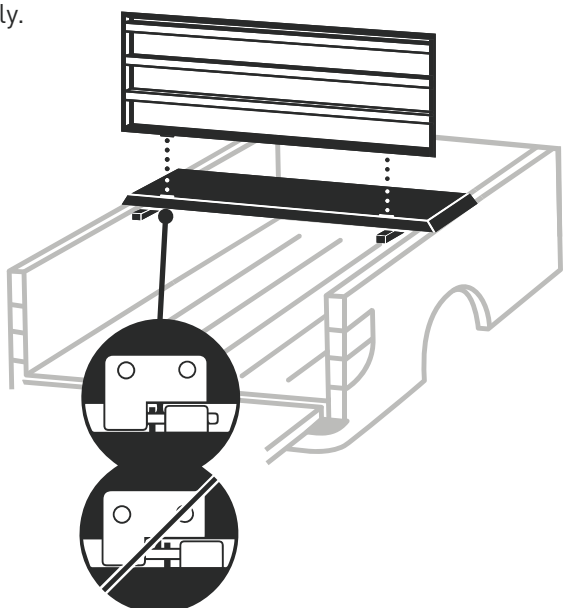

- 4 Repeat step 3 for the **cab panel**. Make sure it doesn't hit your cab.

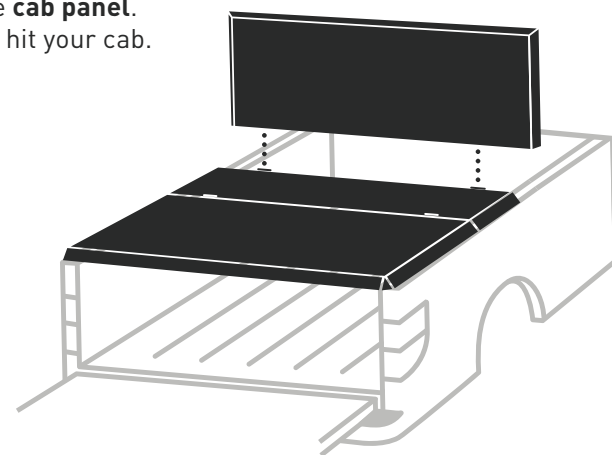

- 5 Position the cover front to back so that the leading edge of the closed cab panel lines up with the leading edge of the bulkhead.

- 6 Center the cover side to side on the truck.

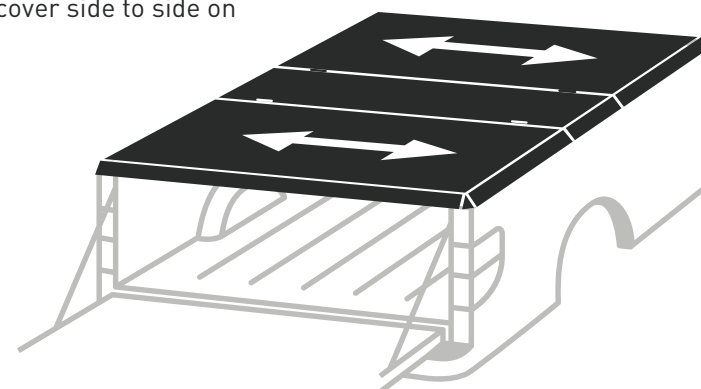

- 7 Tighten the cap clamps with a 9/16" socket.

**!** Retighten your clamps after 100 miles. Check them every time you haul on top.

# ADJUST THE LOCK RODS

**8** If a plastic bed liner or bed rail caps cover the vertical face of your bed rails, prepare them to receive the **bed-rail edge trim** by cutting a rectangular area the size of the trim pieces out of the plastic at each of the four places where a lock rod will pass under the bed rails.

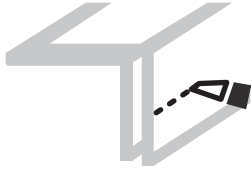

**9** Peel the red adhesive backing from the bed-rail edge trim pieces. Affix one piece of trim to each of the newly cut-out, exposed metal areas of the bed rail.

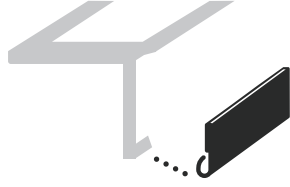

**10** Loosen the set screws on the tailgate-panel lock-rod linkages.

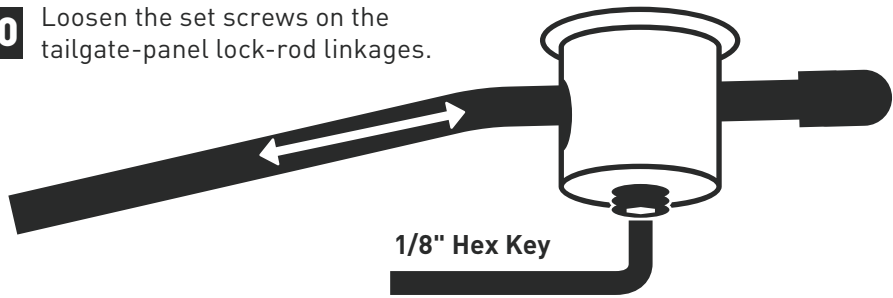

**11** Adjust the length of the lock rods and retighten the set screws so that:

- A. with the lock handle in the open position, the rod tips clear the bed rails,
- B. with the handle in the closed position, the rod tips do not strike the bed walls, and
- C. the rods point downward.

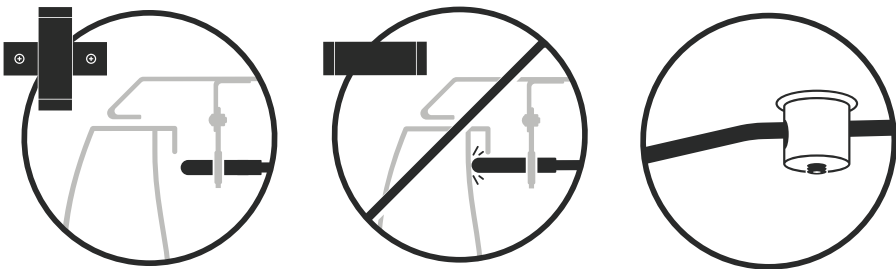

**12** Position the lock rods tight against the underside of the bed rail lips so that they'll draw the panels down and compress the weatherstrip. Tighten the rod guide brackets with a 7/16" socket.

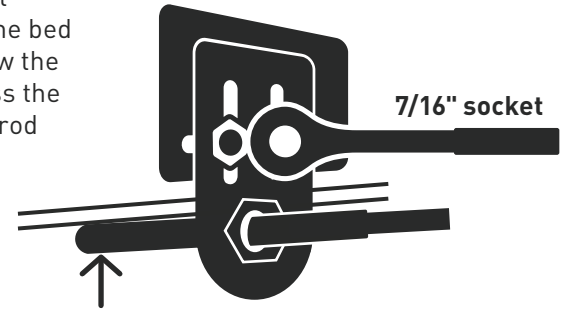

**!** To get the weatherstrip compression necessary for its adhesive to cure and the cover to keep out the weather, have a second person press down on the cover while you're adjusting the lock rods.



**★** Using the access panels is easiest when you press down as you open or close them.



**13** Repeat steps 10 through 12 for the cab panel.

**★** Your panels should be very difficult to operate at first. Leave them closed as much as possible for 3-4 days to break in the weatherstrip. After that period, you should find that the panels open and close without difficulty.

# ATTACH THE SAFETY CATCH & GAS SPRINGS

**14** Fit the **safety catch** around the ball studs on the driver side of the cab panel.

**!** To ensure the safety catch works properly, attach it as shown with its slotted half up and the triangle pointing toward the cab.

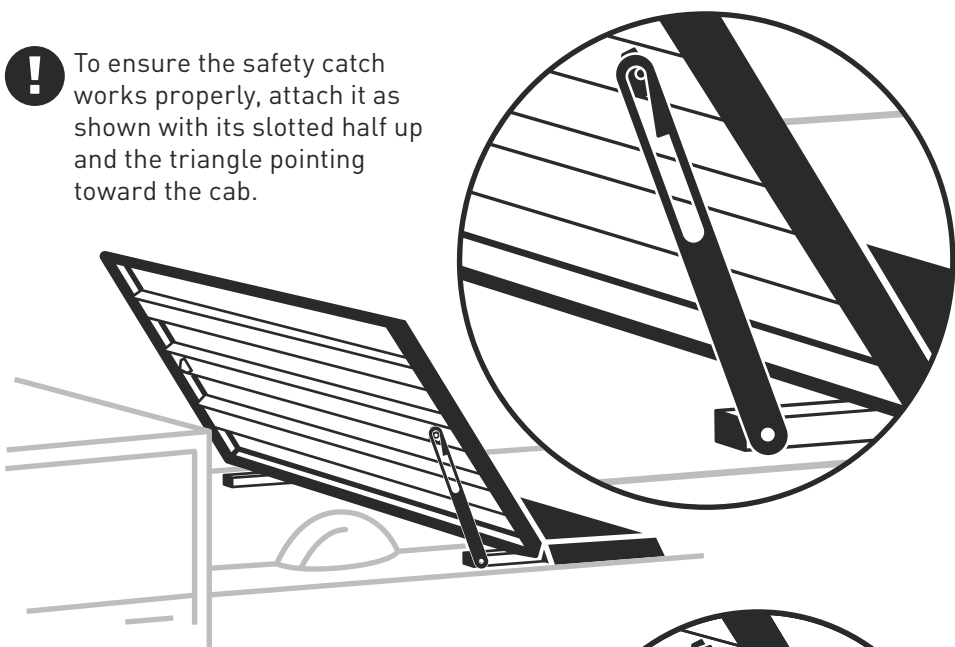

**15** Attach a **gas spring** to the same ball studs.

**!** To avoid premature failure of your gas springs, attach them barrel up, shaft down.

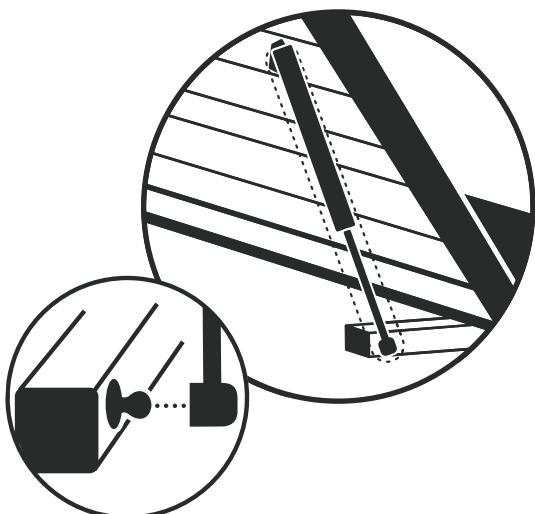

**16** Attach the three remaining gas springs (barrel up, shaft down).

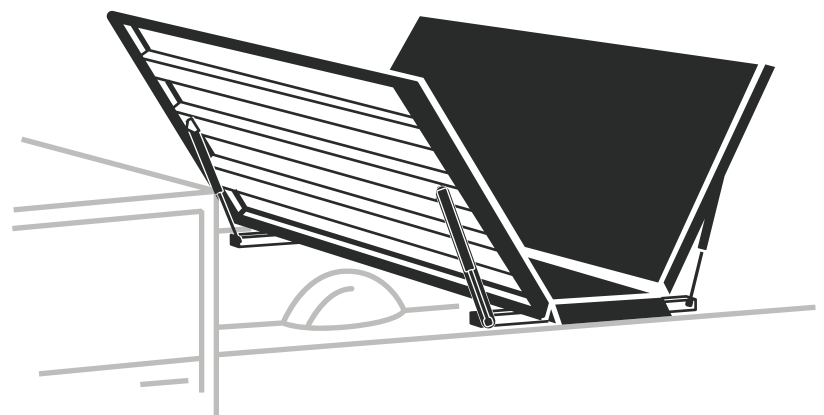

**17** If your truck has bed rail caps, affix the included **bulkhead weatherstrip**. Refer to the **Bulkhead Prep Kit Installation Guide** for details.

**18** Leave the cover closed and locked for 24 hours to allow the weatherstrip adhesive, which is pressure-sensitive, to fully cure.

**24 hours**  
Adhesive Cure Time